



INSTRUCTION MANUAL

ON-OFF ELECTRIC ACTUATOR “AE” TYPE

OMAL S.p.A. Società Benefit

Headquarters: Via Ponte Nuovo, 11 - 25050 Rodengo Saiano (BS) Italy · Production Site: Via Brognolo, 12 - 25050 Passirano (BS) Italy
Ph. +39 030 8900145 · Fax +39 030 8900423 · info@omal.it · www.omal.com

INDEX:

	Pag.
1. WARNING	3
2. FEATURES	4
3. DIAGRAMS AND ADJUSTMENTS	6
4. DIAGRAMS AND ADJUSTMENTS FOR OPTIONAL	9
5. ACCESSORIES AND CONFIGURATION	12
6. DISPOSAL OF PRODUCTS AT THE END OF THEIR LIFE CYCLE 	13
7. STATEMENT OF CONFORMITY	13

 **Environmental friendly:** under the green leaf icon you can find the instructions for a correct and environmentally friendly handling of the product.

FOREWARD

The present User's Installation and Maintenance Manual has been edited in conformity with:
Directive 2014/30/EU (EMC)
Directive 2011/65/UE (RoHS)

Below you will find the safety instructions, the minimum information for storage / warehousing, the installation, the commissioning, the maintenance and the instructions for disposal of products at the end of their life cycle
The actuators have CE marking, according to the applicable European Directives
OMAL S.p.A. disclaims any liability for damage caused by improper use, even if partial, respect to the information contained in this manual.

Note

Please keep this manual in a safe and accessible place.

Always use Individual Protection Devices in compliance with current regulations.

Let only expert and specifically trained staff install and service your system.

Before connecting, please make sure the ground wiring system works properly.

The electric system has to be made in such a way to allow every actuator to have a suitable protection and a disconnecting switch with a key.

Use original spare parts ONLY.

If necessary, spare labels can be provided.

All data and features in this manual may be changed at any time and with no notice for the implementation of technical improvements. Therefore they can not be considered as binding for the delivery.

Made in Japan

OMAL S.p.A. Società Benefit

Headquarters: Via Ponte Nuovo, 11 - 25050 Rodengo Saiano (BS) Italy · Production Site: Via Brognolo, 12 - 25050 Passirano (BS) Italy
Ph. +39 030 8900145 · Fax +39 030 8900423 · info@omal.it · www.omal.com

1. WARNINGS

- Make sure that the actuator torque is compatible with the use it is intended for. Please note that the necessary torque depends not only on the working conditions, but on the safety margins of the plant too. However, a safety factor of 30% min. should be provided for.
- To ensure the correct operation of the appliance, do not alter the construction and electrical connections in any way.
- Create the electrical control and power system so that each actuator is equipped with a selector, or switch, equipped with a key and placed near it.
- Before connecting, check the data on the technical label.
- Before adjusting or servicing in any way, make sure that the actuator has been electrically insulated and that all necessary equipment is at hand.
- Connect in an orderly and precise way, tightening the terminal screws firmly and pressing the cable presses suitably.
- The power supply cable must be at least H05RR-F4G1 (for rubber ones) and H05VV-F4G1 (for PVC ones)
- After connecting, adjusting or servicing in any way, close the caps very carefully to avoid possible infiltrations.
- Do not connect or service in the rain or in splashing water
- Cover the actuator completely, if it is installed in wet locations or where other liquid materials may be contacted.
- Protect the actuator from direct sunlight which may overheat it or cause its malfunctioning.
- In the mounting area, keep some space for maintenance or adjustment operations, if any.
- Before mounting an actuator onto a valve, remove any rotation device or stop and make sure that the fit is perfect and safe.
- The actuator-valve couplings must be made so as to guarantee a perfect fit. As for shafts provided with wrenches, the wrench must be made so as to use up all the space which was intended for it.
- If an actuator is mounted onto a valve which has not been used for long, make sure that the valve is free to rotate, before operating the actuator.
- In case of maintenance wear suitable clothing and protective gloves to avoid direct contact with hot parts
- Handle, stock and transport the actuator with due care not to damage it in any way
- Clean with non-inflammable products only

NOTE: This actuator has not been made in compliance with the Atex Directive: Do not use in places or areas which might be explosive.

OMAL S.p.A. CANNOT BE HELD RESPONSIBLE FOR ANY DAMAGE TO PEOPLE, ANIMALS OR THINGS DUE TO AN IMPROPER USE OF THE PRODUCT

If an electric actuator OMAL is properly assembled and used under normal working conditions, it will be maintenance free as it has been lubricated enough to last a standard working life. Should it get necessary to service or repair it, we suggest applying to OMAL s.a.s where the product will be overhauled first and then tested.

OMAL S.p.A. DECLINES ANY RESPONSIBILITY FOR AND GUARANTEE ON PRODUCTS REPAIRED BY THIRD PARTIES

OMAL will be free to change all specifications and data included in this catalogue at any time, so as to improve the quality and the performance of its products.

2. FEATURES

- Actuator ON-OFF; working angle 90° (100° Max.).
- Service 50%.
- Max. torque from 10 to 1960 Nm (see the table).
- Supply voltage 230 Vac (+-10%) 50/60 Hz 1Ph.
- Insulation resistance 100 MΩ /500 Vdc.
- Tension insulation 1500 Vac/1 minute.
- Motor with Class E insulation.
- Working temperature from -25°C to + 55°C (for use in temperatures below 0°C, we suggest anti-condensate elements).
- Protection level as per NEMA-4X IP66.
- Valve connections from F03 to F14 as per ISO 5211.
- Auto-reset thermostatic protection inside the motor.
- Open/close limit switch with cams adjustable along the wholestroke.
- Safety mechanical limit switches, adjustable.
- Graduated visual position indicator.
- Detachable lever for manual operation.
- Electric connections with screw terminals.
- Locking of supply cables by means of cable gland.
- Maximum noise level during operation <70dB (A).

OPTIONALS

- Supply voltage 115 Vac – 24 Vac (*) – 24 Vdc (**).
- Auxiliary limit switches (standard on AE 10 and AE 40).
- Torque limiters.
- Position potentiometer 135/500/1000 ohms.
- Position convertor R/I 4-20 mA DC (**).
- Speed adjusting unit (**).
- Anti-condensate element.
- Disengagement wheel for manual operation (on AE100 and AE 200, only).
- Drive socket.
- * AE 10-AE 400, only
- ** AE 40-AE 200, only
- *** AE 100-AE 2000, only

FEATURES									
MODEL	AE 10	AE 40	AE 100	AE 200	AE 400	AE 600	AE 1000	AE 1500	AE 2000
Torque Nm	10	39	98*	196	390	590	980	1470	1960
Time of cycle (50 Hz) sec.	4	15	30	30	30	30	30	45	60
Time of cycle (60 Hz) sec.	3,3	12,5	25	25	25	25	25	38	50
Time of cycle 24Vdc sec.	----	9,5	16	30	----	----	----	----	----
Power consumption 230Vac 50/60Hz A	0,4/0,5	0,4/0,5	0,35/0,4	0,55/0,6	0,9/1	1/1,1	1,5/1,6	1,8/1,9	1,9/2
Power consumption 115Vac 50/60Hz A	0,8/0,9	0,8/0,9	0,6/0,7	1,1/1,2	1,9/2	1,9/2	2,9/3	3,4/3,5	3,4/3,5
Power consumption 24Vac 50/60Hz A	1,2/1,3	1,2/1,3	1,7/1,8	2,3/2,4	----	----	----	----	----
Power consumption 24Vdc A	----	2	2,5	2	----	----	----	----	----

* Supply 24 Vdc: 68 Nm

3. DIAGRAMS AND ADJUSTMENTS

Supply diagram for Continuous Current

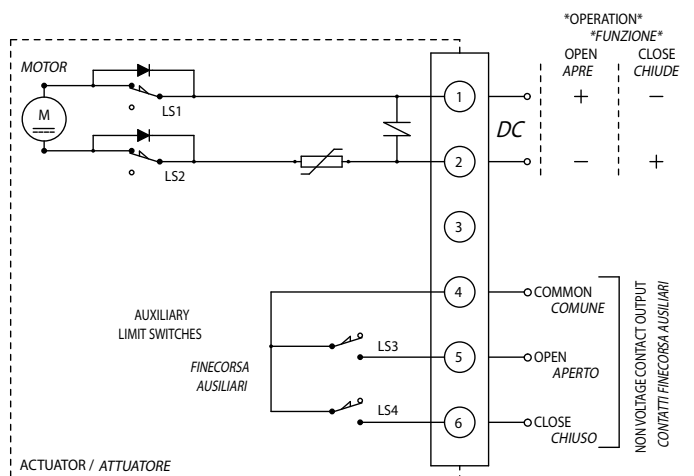

- EXAMPLE OF EXTERNAL CIRCUIT -
- ESEMPIO DI CIRCUITO ESTERNO -

Supply diagram for Alternate Current

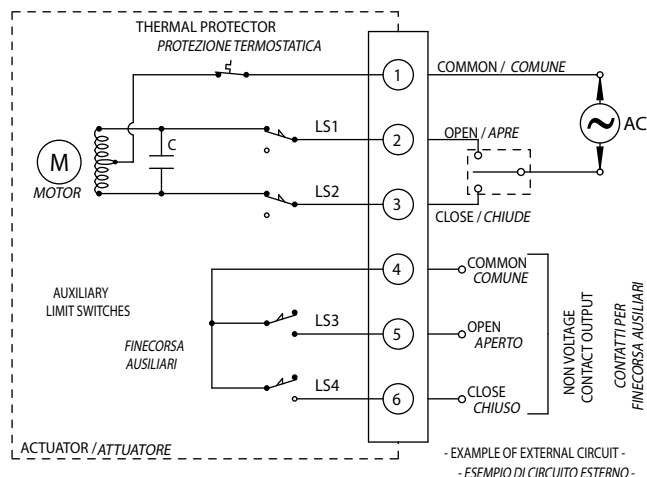

- EXAMPLE OF EXTERNAL CIRCUIT -
- ESEMPIO DI CIRCUITO ESTERNO -

ADJUSTMENT LIMIT SWITCH ACTUATORS AE10-AE40.

Indicatore di posizione
Position indicator

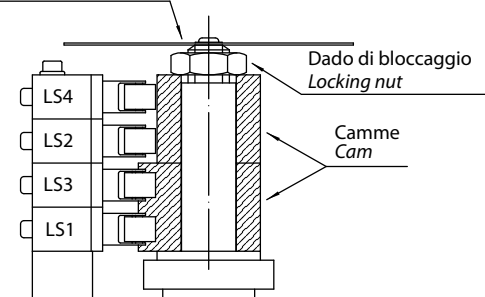

LS1 : opening limit switch.
LS2 : closing limit switch.
LS3 : opening auxiliary limit switch.
LS4 : closing auxiliary limit switch.

- Isolate the actuator from electricity.
- Disconnect the position indicator.
- Loosen the cam lock nut.
- Make the actuator rotate, by using the hand lever, in order to completely open the valve.
- Adjust the lower cam, making sure that the LS1 limit switch is pressed.
- Do the same for the closed position and check the LS2 limit switch.
- Tighten the cam lock nut; by doing this, the auxiliary limit switches LS3 and LS4 will also be adjusted.
- Reinstall the position indicator, by making it match with the state of the valve.

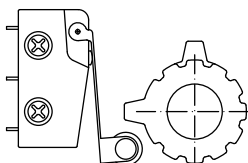

SPDT type auxiliary limit switches, max load:
AC3 = 5A 250Vac
AC1 = 1.5A 250Vac

ADJUSTMENT LIMIT SWITCH ACTUATORS AE 100~2000.

AE 100

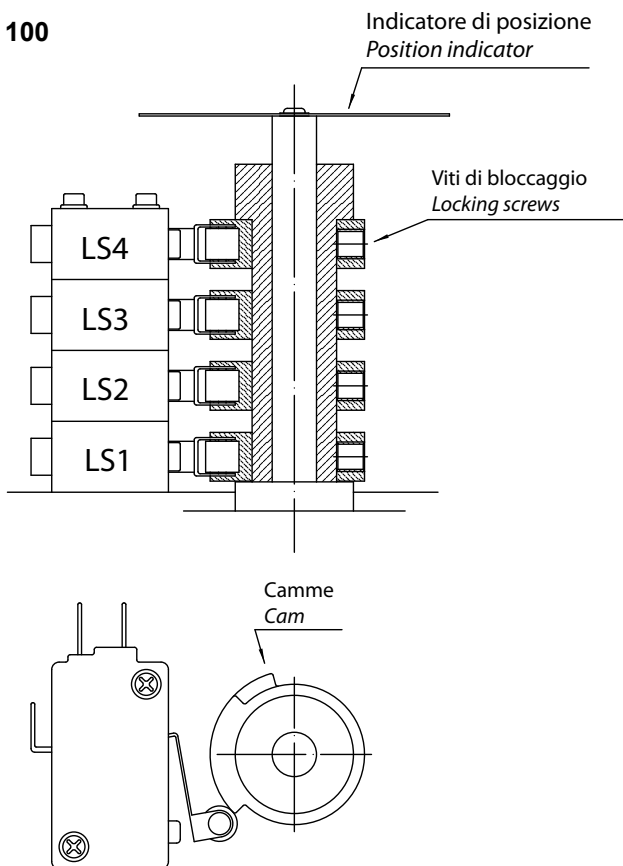

LS1: opening limit switch.
LS2: closing limit switch.
LS3: opening auxiliary limit switch.
LS4: closing auxiliary limit switch.

- Isolate the actuator from electricity.
- Disconnect the position indicator.
- Loosen the cam lock screws.
- Make the actuator rotate, by using the hand lever, in order to completely open the valve.
- Adjust the lower cam, making sure that the LS1 limit switch is pressed.
- Do the same for the closed position and check the LS2 limit switch.
- Tighten the cam lock screws.
- Reinstall the position indicator, by making it match with the state of the valve.

Note: in order to adjust the auxiliary limit switches, LS3 and LS4, do the same as the above.

V5 SPDT type auxiliary limit switches, max load:
AC3 = 3A 250Vac
AC1 = 10A 250Vac

AE 200-400

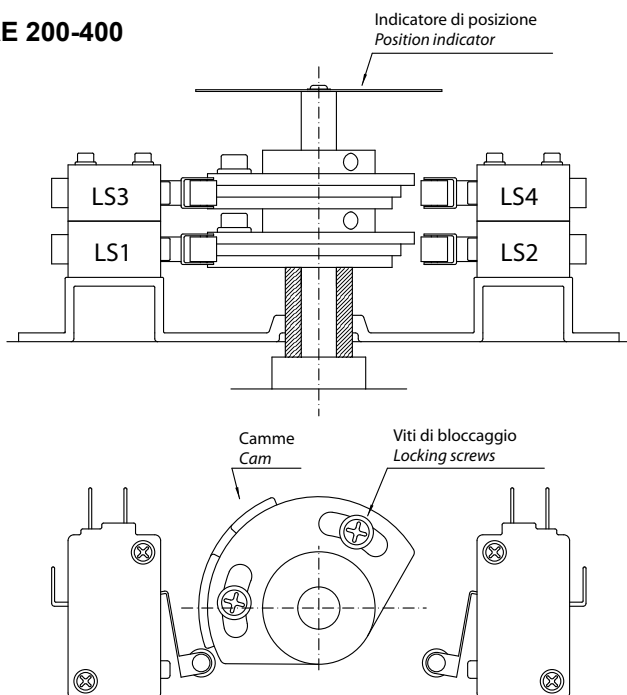

AE 600÷2000

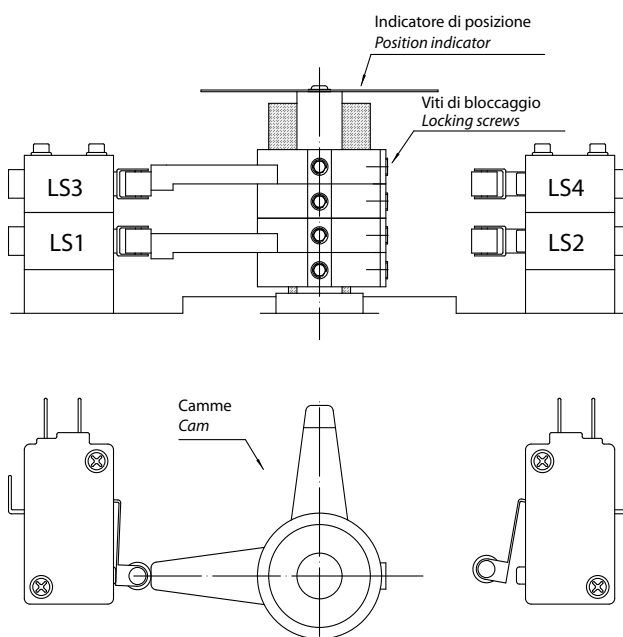

Mechanical safety limit switch

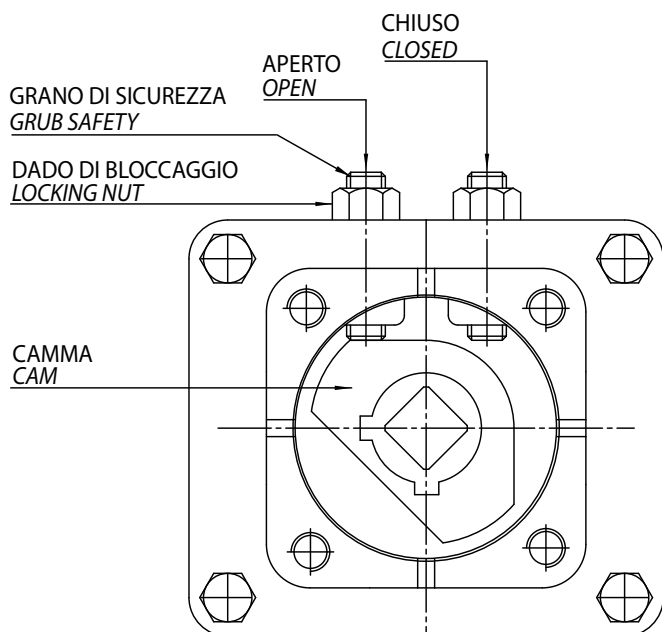

After adjusting the position limit switches, the safety mechanical limit switches also need to be adjusted; please proceed as follows:

- Isolate the actuator from electricity.
- Loosen the lock-nuts of the safety grub screws.
- Unscrew both grub screws.
- By using the manual drive lever, make the actuator rotate so to open the valve completely.
- Screw in the opening safety grub screw up against the cam and then unscrew it by half a turn.
- Tighten the lock-nut while holding the grub screw still.
- Repeat the same procedure for the closed valve position.

Caution: the safety mechanical limit switches must set in only in case of failure to the position limit switches.

Manual drive lever

- Isolate the actuator from electricity.
- Unscrew the screws that connect the lever to the actuator body.
- Insert the lever in the hexagon shape seat.
- Turn the lever in a counter clock-wise direction in order to turn the actuator towards the valve opening point.
- Turn the lever in a clock-wise direction in order to turn the actuator towards the valve closing point.
- Place the lever in its connection point on the actuator.
- Screw in the screws that connect the lever to the actuator body.

Caution: insert the lever only when using the actuator in manual mode and remove it after the maneuvers.

Caution: in case the valve is stuck, do not use the lever to force it to move.

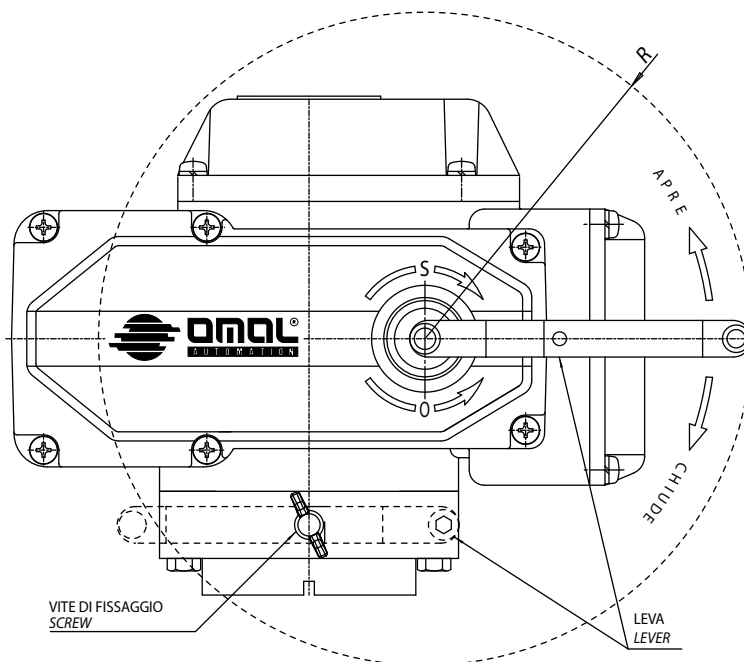

MODEL	AE 10	AE 40	AE 100	AE 200	AE 400	AE 600	AE 1000	AE 1500	AE 2000
Hexagonal wrench mm.	5	5	5	6	6	10	10	10	10
Number of turns (90°)	7,5	7,5	15	15	15	15	15	15	15
Radius R mm.	106	106	106	124	124	241	241	241	241

4. DIAGRAMS AND ADJUSTMENTS FOR OPTIONALS

Close and open torque limiter

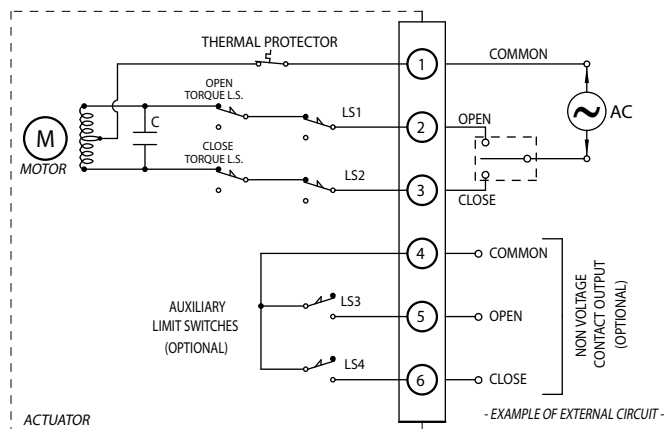

Close torque limiter

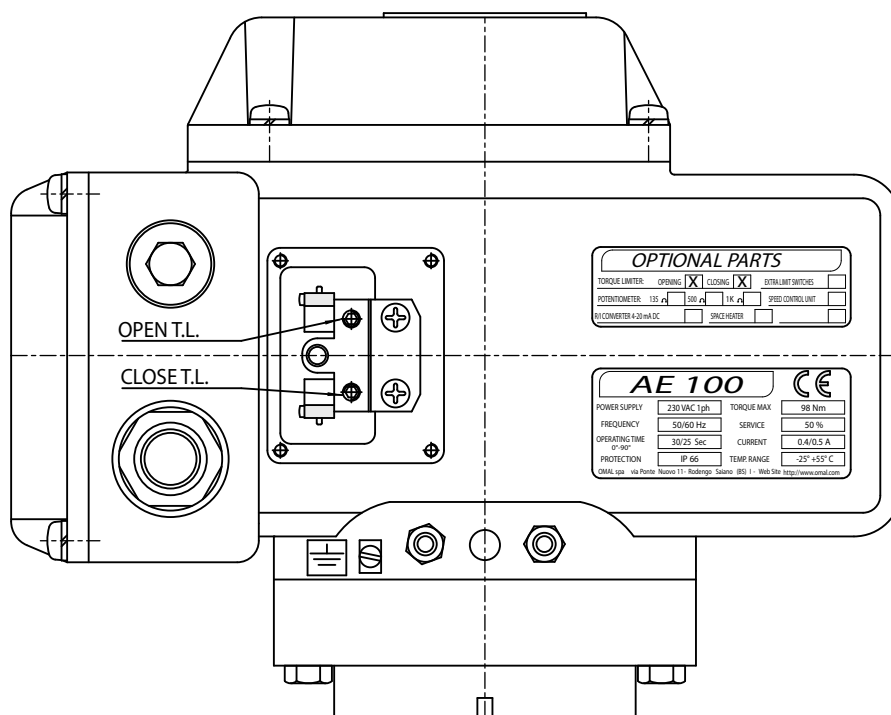
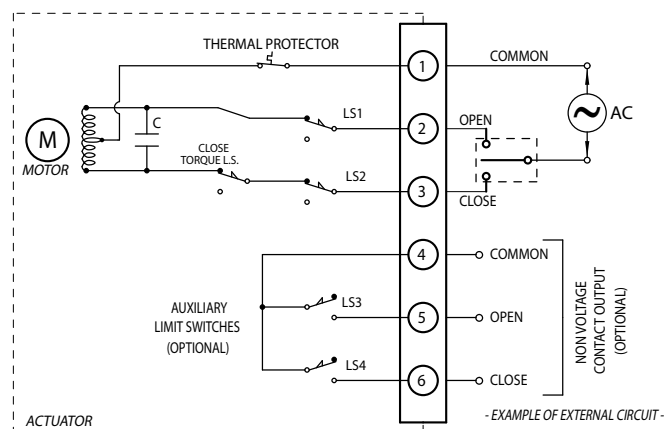

When ordering, please specify the torque value for which the limiters are to be set: the actuator is designed according to the customer's specifics before shipping, in order to ensure a perfect setting. However, if necessary, it is possible to adjust the set value by following the steps listed below.

- Opening limiter: by turning the screw in the clockwise direction, the torque will increase; by turning the screw in the counter-clockwise direction the torque will decrease.
- Closing limiter: by turning the screw in the clockwise direction, the torque will decrease; by turning the screw in the counter-clockwise direction the torque will increase.

CONVERTORN R/I

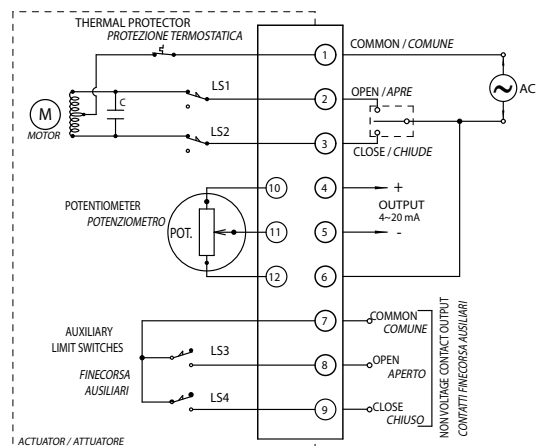
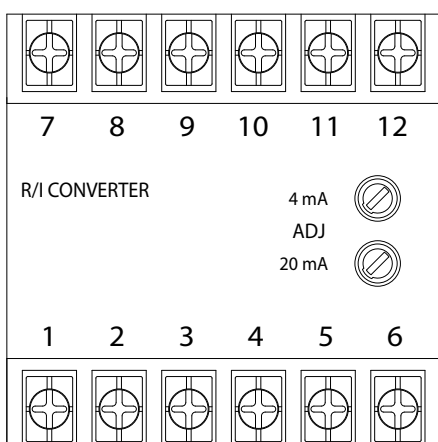

- EXAMPLE OF EXTERNAL CIRCUIT -
- ESEMPIO DI CIRCUITO ESTERNO -

Allows to obtain a 4~20 mA output signal, proportional to the position of the actuator, in order to monitor the state of the valve.

ADJUSTMENT

By means of the two potentiometers, it is possible to optimize the output current corresponding to the closed and open positions of the valve:

- Apply a milliammeter to terminals 4 and 5.
- Make the actuator rotate to the "open" position and adjust the output current to 20mA.
- Make the actuator rotate to the "closed" position and adjust the output current to 4mA.

SPEED ADJUSTMENT

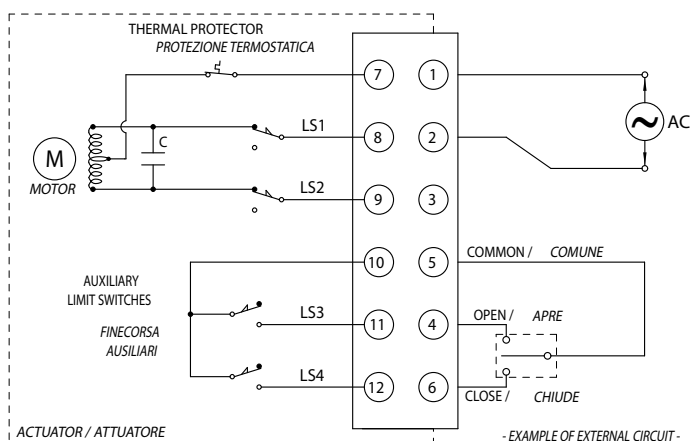
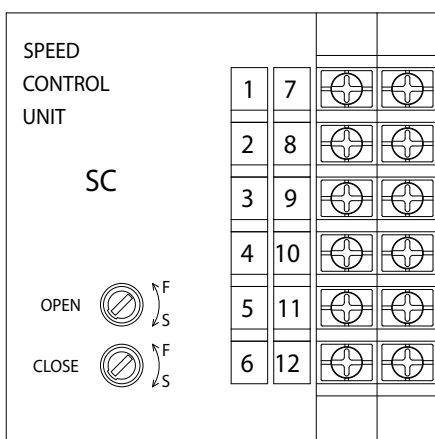

- EXAMPLE OF EXTERNAL CIRCUIT -
- ESEMPIO DI CIRCUITO ESTERNO -

Allows to increase the maneuver time on 90°, in an independent way for opening and closing:

- from 30 to 240 seconds for AE100~AE1000 actuators.
- from 45 to 255 seconds for AE1500 actuators.
- from 60 to 270 seconds for AE2000 actuators.

Make the potentiometer rotate in a clock-wise direction in order to increase the rotation time.

Make the potentiometer rotate in a counter clock-wise direction in order to decrease the rotation time.

POTENTIOMETER

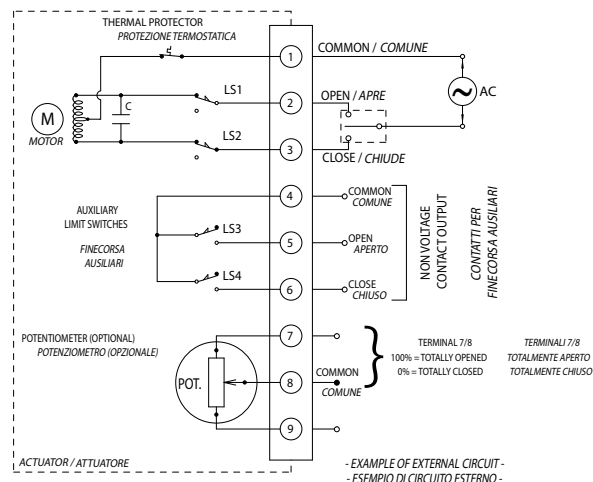
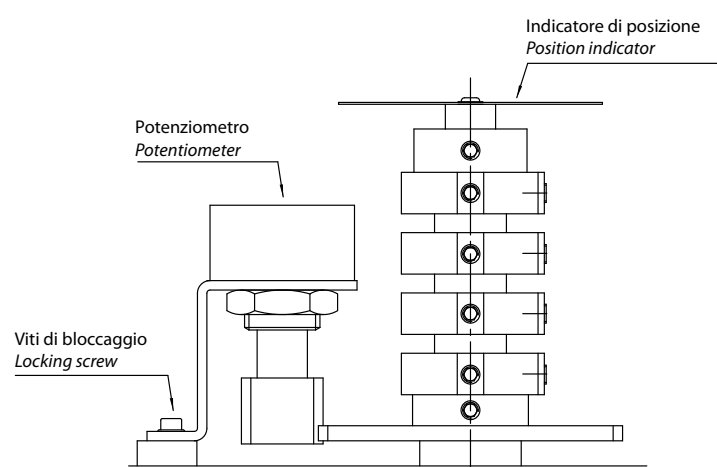

Allows to detect the actuator position in order to monitor the state of the valve.

The potentiometer is already adjusted when supplied; in the case a further adjustment is needed, please proceed as follows:

- Isolate the actuator from electricity.
- Disconnect the position indicator.
- Loosen the lock screws of the potentiometer holder bracket.
- By using the manual drive lever, make the actuator rotate so to open the valve completely.
- Connect the terminals of an OHM meter to terminals 7 and 8 of the terminal board and manually adjust the potentiometer to the desired value.
- Reposition the potentiometer holder bracket and fasten the lock screws.
- Reinstall the position indicator, by making sure it matches with the state of the valve.

NOTE: there are three resistance values available: 135, 500, 1000 Ohm.

5. ACCESSORIES AND CONFIGURATION

EXTRA ACCESSORIES FOR ELECTRIC ACTUATORS "AE" TYPE	
DESCRIPTION	CONFIGURATOR
Potentiometer 135 ohm	P1
Potentiometer 500 ohm	P2
Potentiometer 1000 ohm	P3
Convertor 4÷20 mA	RI
Speed control	SC
Close torque limiter	T1
Close and Open torque limiter	T2
Anti-condensate element	SH
Wheel for manual operation	HW

NOTE: All extra accessories must be requested when placing the order. The actuator will be provided with its accessories while being assembled and, therefore, it will not be possible to change its original configuration.

MAXIMUM CONFIGURATION FOR THE SUPPLY OF ACTUATORS							
	AP(1-2-3)	AT1/AT2 AT5/AT6	ASH	ARI	ASC	AHW	AL2
AE 10 - AE 40 Tensione Voltage AC - DC	YES	YES (T1)	YES	NO	NO	NO	STD
AE 100 - AE 200 Tensione Voltage AC	YES	YES	YES	NO	YES	YES	STD
AE 100 - AE 200 Tensione Voltage AC	NO	YES	YES	YES	NO	YES	STD
AE 100 - AE 200 Tensione Voltage DC	YES	YES	YES	NO	NO	YES	STD
AE 400 ÷ AE 2000 Tensione Voltage AC	YES	YES	YES	NO	YES	NO	STD
AE 400 ÷ AE 2000 Tensione Voltage AC	YES	YES	YES	YES	NO	NO	STD

Legenda

STD = standard accessory
 SI = available accessory
 NO = not available accessory

6. DISPOSAL OF PRODUCTS AT THE END OF THEIR LIFE CYCLE

The OMAL products are designed so that when they are at the end of life cycle they can be completely disassembled, separating the different materials for the proper disposal and/or recovery.

All materials have been selected in order to ensure minimal environmental impact, health and safety of personnel during their installation and maintenance, provided that, during use, they are not contaminated by hazardous substances.

The personnel in charge of the product disposal/recovery, must be qualified and equipped with appropriate personal protective equipment (PPE), according to the product size and the type of service for which the device was intended.

The management of waste generated during the installation, maintenance or due to the product disposal, is governed by the rules in force in the country where the product is installed.

Products marked with this symbol, at End of life, must be taken to a separate disposal for electrical and electronic devices in order to recover recyclable materials (metals, plastics, glass, etc.) and to safely dispose of any polluting materials.



Abandonment in the environment or illegal disposal of this equipment is punished by law

This equipment falls within the scope of the Directive 2012/19/EU on Waste Electrical and Electronic Equipment (WEEE).

The equipment must not be disposed as a mixed urban waste, it must be recycled via the dedicated collection system for disposal and its subsequent correct recycling of WEEE

The collection system of the equipment at the End of life is guaranteed, on the national territory, in case of disposal or purchase of an equivalent equipment, through the national consortia for the eco-sustainable management of WEEE. For information contact OMAL SPA.

The product at the End of life, if properly disposed of, is not potentially dangerous for human health and the environment, otherwise it could have a negative impact on the ecosystem

The packaging materials that come with the product, should be transferred to the differentiated collection system available in the country.

7. STATEMENT OF CONFORMITY

The OMAL S.p.A. actuators have been designed, manufactured and tested to meet the requirements of the following European standards and are marked, where provided, with the relative CE conformity marking:

- Directive 2014/30/EU (EMC)
- Directive 2011/65/EU (RoHS)